

PROMETHEAN AB+2 PROJECTOR MAINTENANCE

Cleaning Filters

As per manufacturer recommendations the ceiling mounted projectors need to be cleaned on a regular basis. ACT recommends filters are checked and cleaned every two weeks. Some classrooms will be able to extend this timeline to once a month. Heating and air filtering systems in the classroom will determine just how often you need to clean the filter. Ceiling projectors tend to collect a larger amount of dust due to the position of the filters as you can see in the following pictures:

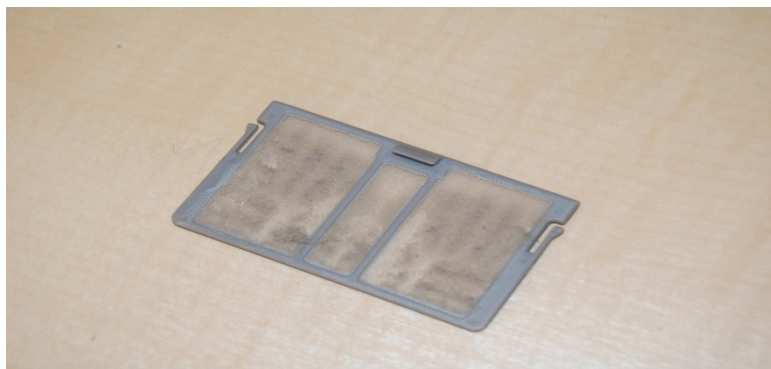

This is the AB+2 filter after one month.



This is what the filter looks like after cleaning.

FILTER LOCATIONS

AB+ 2 (Front and Rear filters)



Cleaning the Air Filters

Air filters prevent dust from accumulating on the optical elements inside the projector. Should the air filters become clogged with dust particles, it reduces cooling fans' effectiveness and may result in internal heat build up and adversely affect the life of the projector. Clean the air filters following the steps below.

- 1** Turn off the projector, and disconnect the AC power cord from the AC outlet.
- 2** Turn over the projector and remove the air filters by pulling the latches upward.
- 3** Clean the air filters with a brush or rinse them softly.
- 4** When cleaning the air filters by rinsing, dry them well. Replace the air filters properly. Make sure that the air filters are fully inserted.



CAUTION

Do not operate the projector with the air filters removed. Dust may accumulate on the optical elements degrading picture quality. Do not put small parts into the air intake vents. It may result in malfunction of the projector.

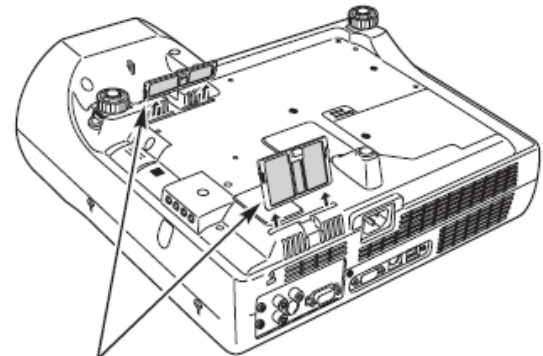

Air filters
Pull up and remove.

✓ **Note:**

- When reinserting this air filter, be sure that the slit part is facing the outer side.